

Floor Expansion Joint Covers

i412[®]



Description

The **i412[®]** floor expansion joint system is a pan system designed for generous thermal and seismic movement requirements and narrow sight lines that minimize aesthetic disruption to flooring finishes.

Key Features

- **Install Condition:** Floor/Floor, Floor/Wall.
- **Joint width:** 50-250mm.
- Optional fire rated.
- Seamlessly integrates with coordinating Wall system.
- Anti-slip surface serrations.
- Applicable for existing conditions, additions and new construction.
- Mill finish aluminum.

Materials

Aluminum: Alloy types of 6061-T6, 6063-T6, 6005A, or 5052-H32 sheet goods.

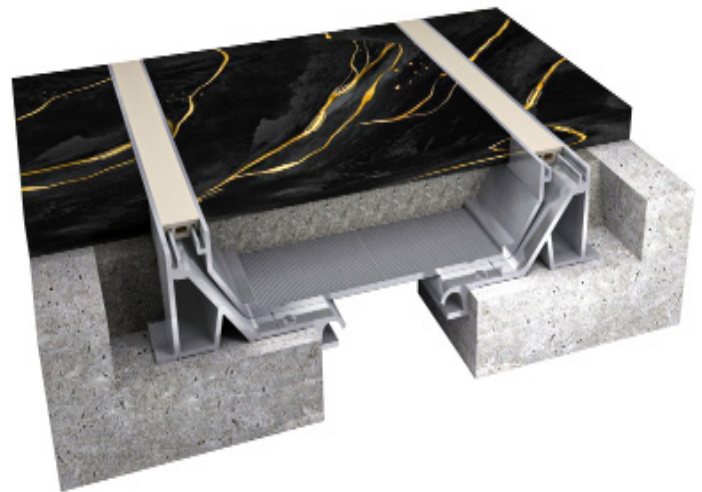

Application Instructions

Installation: Joint systems: Install in accordance with manufacturer's instructions.

Align work plumb, level and flush with adjacent surfaces. Mechanically anchor to substrate. Allowances should be made where actual structural gap at time of installation varies from nominal design gap. No shimming of frames is permitted. Coordinate with work of other Sections.

If concrete blockouts (rebates) are required, ensure continuous support equal to surrounding substrate structural values.

Fire Rated Assemblies: Where required, install to manufacturer's instructions.

Moisture Barrier: Where required, install to manufacturer's instructions.

Floor Expansion Joint Covers

i412[®]



Protect: the completed Expansion Control system work from damage during construction. Damage protection includes surface abrasion and overloading of coverplate by materials handling equipment and construction waste/debris. Protection from environmental factors required throughout installation process until Project Closeout. Protection includes but is not limited to rain events, moisture protection, exposure to temperature fluctuations or direct sunlight for temperature sensitive product offerings.

Store

Store components in original containers in a clean, dry location. Ensure temperature or moisture sensitive components are stored in a tempered location.

Contractor to provide temporary protective covers on all installed finished surfaces. Protection is required to guard against both surface abrasions as well as overloading of horizontal deck components by construction traffic .

Movement ± 50%

Application	System	W	H1	H2	S	B	Movement +/-		L
		Joint Width	Frame Height 1	Height 2	Sightline	Blockout	Horizontal	Vertical	Load
		mm	mm	mm	mm	mm	mm	mm	Kn
Floor to Floor	i412-50	50	55	*	65	125	25	50	45
	i412-100	100	55	*	65	125	50	50	45
	i412-150	150	55	*	65	125	75	50	45
	i412-200	200	55	*	65	140	100	50	45
	i412-250	250	55	*	65	175	125	50	45
Floor to Wall	i412-C-50	50	55	*	32	175	15	50	45
	i412-C-100	100	55	*	32	150	25	50	45
	i412-C-150	150	55	*	32	125	35	50	45
	i412-C-200	200	55	*	32	140	50	50	45
	i412-C-250	250	55	*	32	175	65	50	45

Series i412 - Floor to Floor

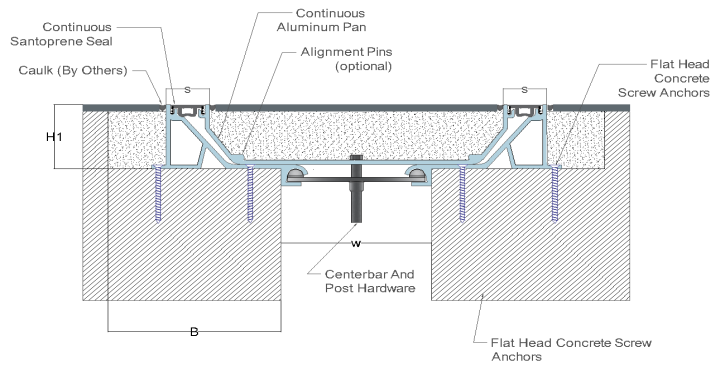

Series i412 C - Floor to Wall

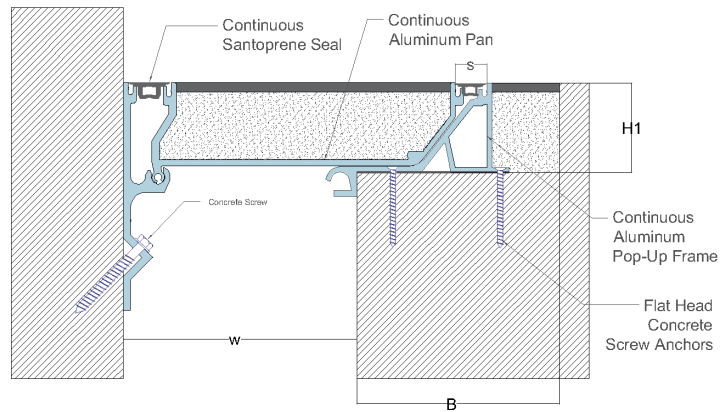

Series i412- Mineral Wool & Sealant Fire Barrier Options

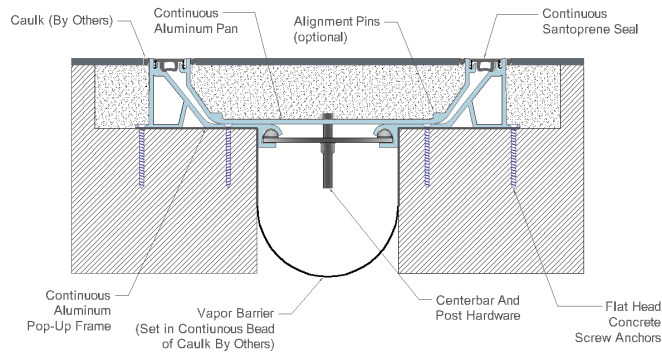

Series i412- FireStop S30 Options

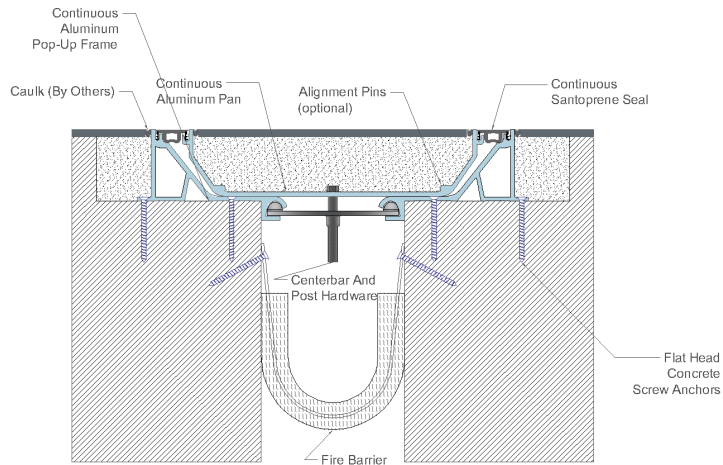

Technical Data Sheet - January 2024, Version 1.1.5

