



Installation Instructions

iFlex CS[®]



Preparation of the Work Area:

1. Please read through entire instructions before installation.
2. Make sure the width and depth of the joint face are 90 ° to the slab's surface.
3. Measure along length of joint to ensure opening is correct size for joint material.
4. Remediate deviations that exceed product tolerances.
5. To ensure successful installation, clean the blockout/joint edge of all contaminants and impurities.

Installation Instructions Steps:

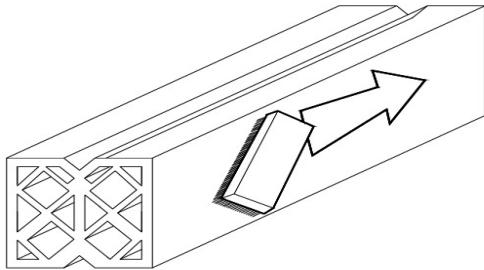

1. Use a wire brush scrub the sides of the iFlex CS
2. Using a small brush, apply primer to the entire length of both ribbed side walls
3. Allow primer to dry for 15 minutes minimum to improve adhesion with joint opening

4. Line the edge of the structural joint with 2" wide tape
5. make sure seal is installed to proper depth

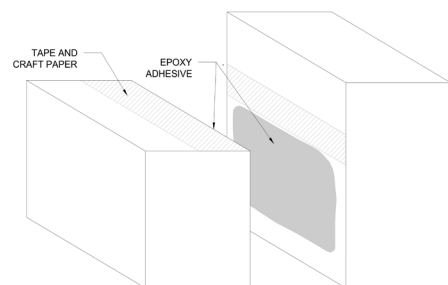

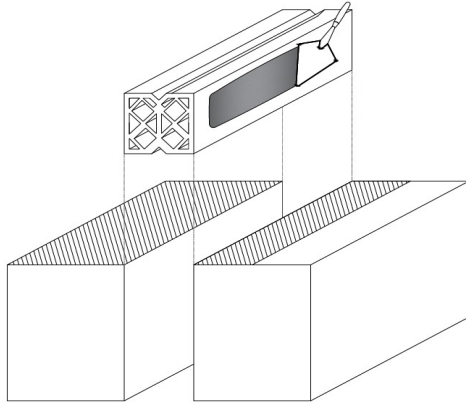

5. Apply primer directly to side of seal prior to mixing the epoxy
6. Epoxy should be applied to both the inside joint walls and ribbed walls of the seal using a margin trowel or chip brush

7. Compress seal and insert into expansion joint .Allow the adhesive to cure 24 hours opening
8. As seal is installed, clean the visible surface and ensure epoxy has been filled flush to top surface
9. Once installation is complete, remove tape from joint edge.Clean any adhesive off of joint surface

