

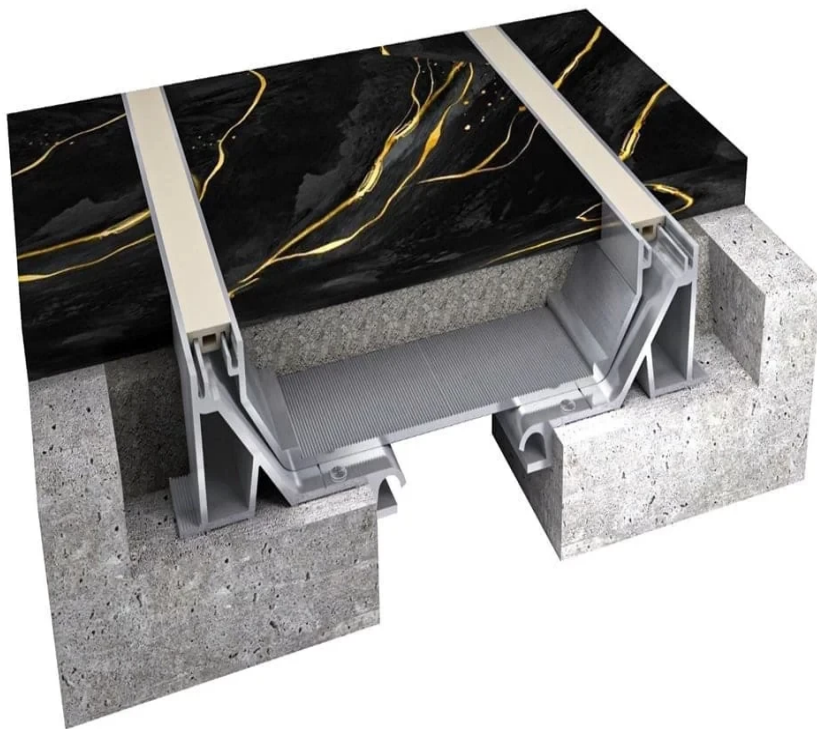

Installation Instructions

i412[®]



Preparation of the Work Area:

1. Please read through entire instructions before installation.
2. Make sure the width and depth of the joint face are 90 ° to the slab's surface.
3. Measure along length of joint to ensure opening is correct size for joint material.
4. Remediate deviations that exceed product tolerances.
5. To ensure successful installation, clean the blockout/joint edge of all contaminants and impurities.

Installation Instructions Steps:

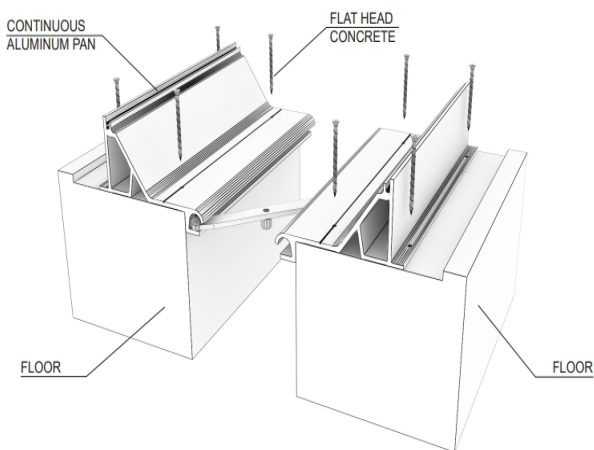

1. Install the architectural joint system on a level surface. To determine blockout depth deduct the thickness of the floor finish from the frame height. This may require adding epoxy based leveling compound to raise the tops of the frames
2. Cut the aluminum plates to the desired length
3. Remove the center pan from the frames and re-position the recessed frames in-line with the marked lines, and mark the hardware locations on the concrete

4. Mark the pre-drilled hole locations on the substrate
5. Remove the frames from the concrete and drill the marked hole locations
6. Return frames to position and fasten in place using the supplied flat head concrete Anchor

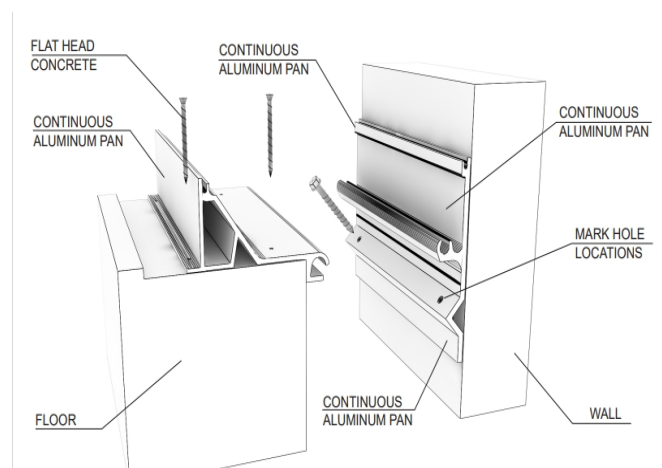

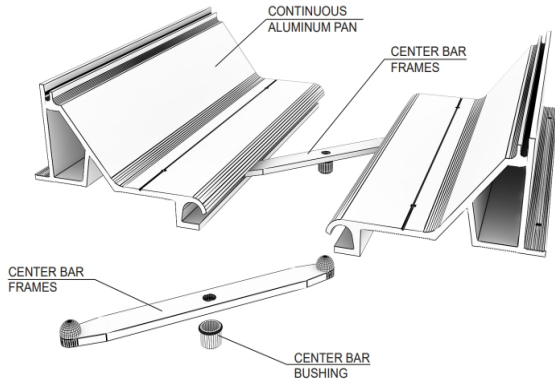

7. Cut the provided center bar frames to appropriate length
8. Position the center bar frames in the joint opening and use the pre-drilled holes to mark the hardware locations on the concrete
9. Assemble the center bar frames with seven centering bars per frame

10. Assemble the center bar hardware with the centerpan. Insert the hex head bolt through the pre-drilled hole in the center pan. Securely fasten the threaded metal post to the bolt

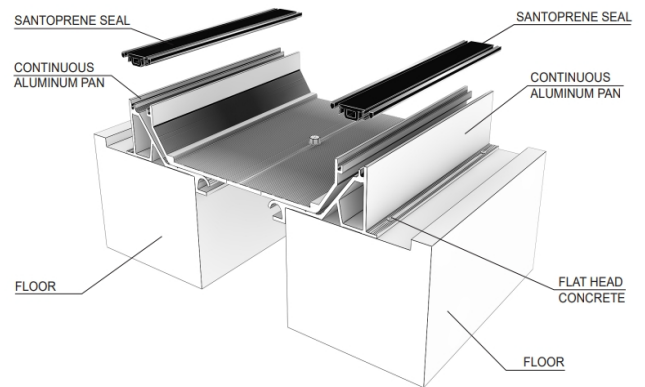

11. Install the santoprene seals on both sides of the expansion joint system

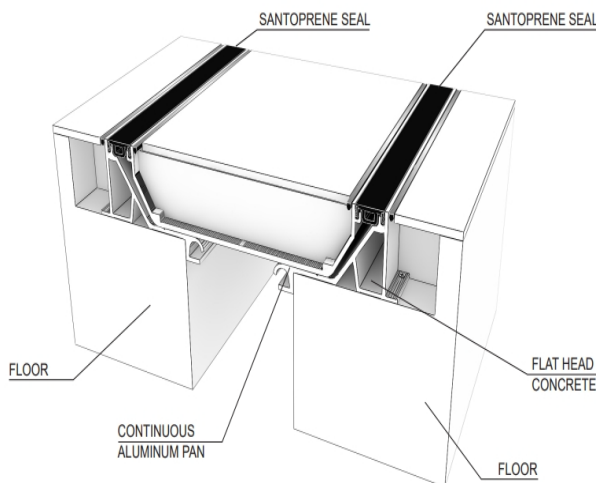

12. Backfill blockout at outside frames with epoxy grout. Ensure the top seals of the expansion joint are centered and protected from construction traffic solvent-based cleaners and other chemicals

